

HERO® 250H-EC Fresh Air Appliance

Top duct connection HRV, 263 cfm, ENERGY STAR®, EC motors

Item #: 463254

Variant: 120V 1~ 60Hz



Powered by EC motors, the **HERO 250H-EC** fresh air appliance provides a controlled way of ventilating a home without excessive heat losses.

- Up to 252 cfm of supply air @ 0.4 in. wg.
- Up to 80% heat recovery to temper the incoming fresh air
- 6" top-mounted connections with rubberized duct seals
- Unobstructed front access for fast & easy maintenance
- Energy-efficient counterflow core to provide exceptional performance
- Multi-speed operation to provide exact airflow
- TurboTouch function boosts exhaust capacity for 20, 40, or 60 minutes
- ENERGY STAR® Certified
- Compatible with the ECO-Touch® Auto IAQ Programmable Wall Control
- Limited warranty (limited lifetime on counterflow core, 7 years on the motor, and 5 years on parts)

Nowadays, new homes utilize a tighter envelope and require mechanical ventilation to remove excess moisture, odors, and contaminants, and provide fresh air for occupants.

Older homes provide a natural infiltration of fresh air through gaps & cracks in the building envelope which consequently results in large losses of heat.

Our **HERO** series of fresh air appliances supplies fresh, filtered air into an indoor space while simultaneously removing an equal amount of moist, stale air.

This appliance recovers up to 80% of the energy from the extract air and uses it to temper the incoming fresh air, optimizing the energy required to pre-cool or pre-heat the newly introduced air.

In the Box

This appliance comes with a wall mount, external electrical box with easy connect ports, integrated in-door manometer ports, and duct ports with plastic collar shrouds with integrated backdraft for simple, fast installation.



Technical parameters

Product		
Voltage (nominal)	120	V
Frequency	60	Hz
Phases	1~	
Input power	230	W
Input current	6.4	A
Air flow	max 263	cfm
Static pressure	0.4	in.wg
Certificate	CSA, HVI, ENERGY STAR	

Exchanger		
Heat exchanger	Heat recovery	

Dimensions and weights		
Weight	57.5	lb

Used for		
Installation type	Vertical	

Performance

Supply - Performance curve

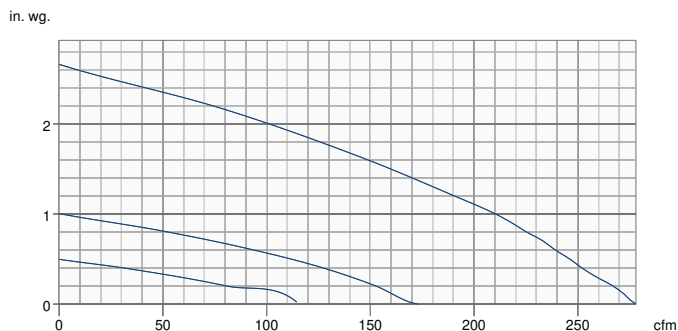

Extract - Performance curve

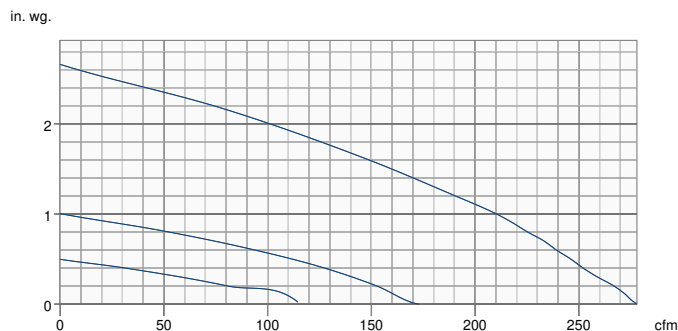

Unit	Supply	Extract
Required air flow	-	-
Working air flow	-	-
Required external pressure	-	-
Working air pressure	-	-
Power	-	-
Current	-	-
Air density	0.075 lb/ft³	
Fan control - RPM	-	-

Performances

	Supply temperature	Net airflow	Consumed power	Sensible recovery efficiency	Adjusted sensible recovery efficiency	Latent recovery / moisture transfer
	°F (°C)	cfm (L/s)	W	%	%	
Heating	32 (0)	85 (40)	34	82	85	0.00
	32 (0)	159 (75)	97	76	80	0.00
	32 (0)	233 (110)	246	72	79	0.00
	-13 (-25)	83 (39)	65	63	65	0.15

Dimensions

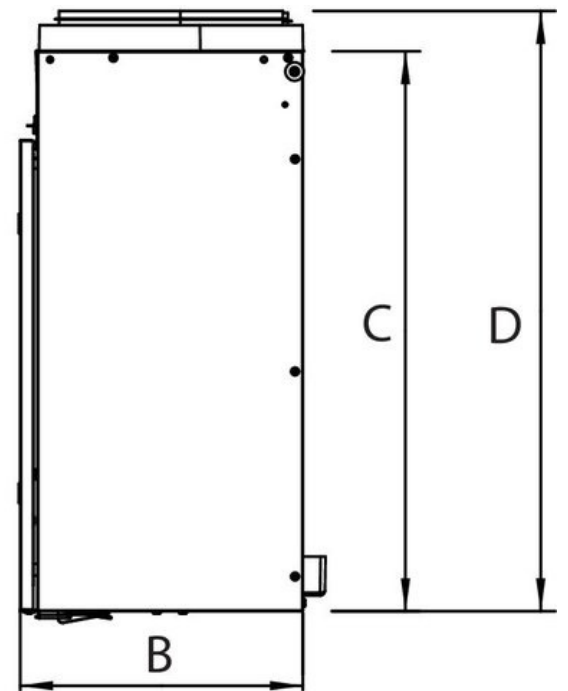
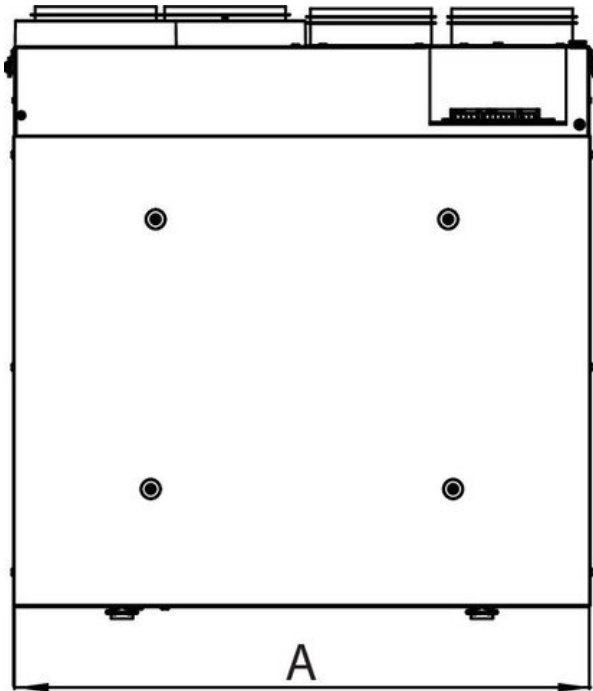

Model	A	B	C	D	Duct Size
HERO 120H	23 1/4 (590)	11 1/2 (291)	22 5/8 (575)	24 1/4 (616)	5 (127)
HERO 150H	27 7/8 (707)	13 3/8 (341)	23 (285)	24 7/8 (626)	6 (152)
HERO 200H	27 7/8 (707)	15 3/8 (391)	23 (285)	24 7/8 (626)	6 (152)
HERO 150H-EC	27 7/8 (707)	13 3/8 (341)	23 (285)	24 7/8 (626)	6 (152)
HERO 250H-EC	27 7/8 (707)	15 3/8 (391)	23 (285)	24 7/8 (626)	6 (152)

Dimensions in inches (mm).

Wiring

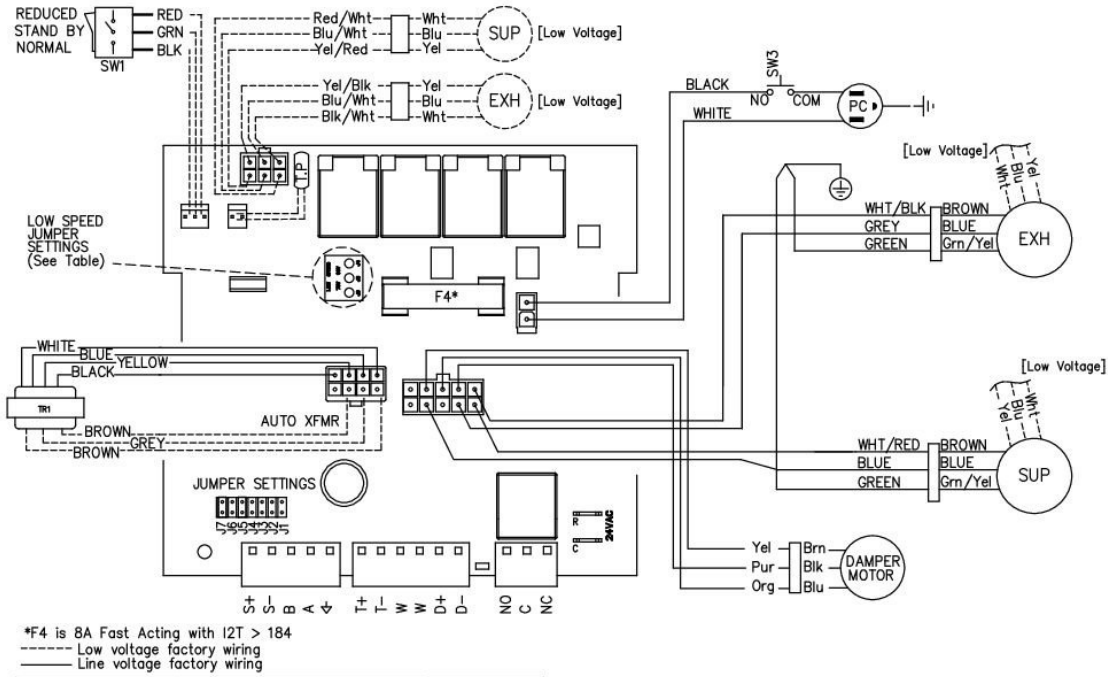

*F4 is 8A Fast Acting with I2T > 184
 ----- Low voltage factory wiring
 _____ Line voltage factory wiring

Model	JUMPER SETTINGS							Low Speed Jumper Settings
	J7	J6	J5	J4	J3	J2	J1	
HERO 150H-EC	ON	ON	ON	OFF	OFF	ON	OFF	75V
HERO 250H-EC	ON	ON	ON	OFF	ON	ON	OFF	

Ecodesign

Basic unit	
Air flow, max [m ³ /h]	147 cfm

Accessories

- CO2RT-R Control (99315)
- ECO-Feel® Auto IAQ control (414729)
- RTS-W Wireless timer (414920)
- FIDT 6 Insulated Flex Duct (411064)
- Filter,MERV13,HERO200,Repl.kit (428549)
- MGE 6 Metal Exhaust Grill (411371)
- FID Display, Trim Kit (464000)
- Contractor Commissioning Kit (463311)
- ECO-Touch® Auto IAQ control (414727)
- COM6P Supply and Exhaust Hoods (40222)
- Filter,HEPA,HERO200H,Repl.kit (428552)
- Filter,MERV8,HERO200H,Repl.kit (428527)
- MGS 6 Metal Supply Grill (411242)
- FID Module, Rough-in Kit (463988)

Documents

- E1934 HERO Brochure.pdf
- E400062 HERO 200H-250H Dimensional Submittal.pdf
- 428486 HERO IOM EN FR.pdf
- HERO Series Spare Part List.pdf
- HERO 200H - 250H-EC Dimensional Drawings.dxf
- 444783 HERO 250H-EC Spec Sheet.pdf

CSI Specification

GUIDE SPECIFICATION

Specifier Notes: This guide specification is written in Construction Specifications Institute (CSI) 3-Part Format in accordance with The CSI Construction Specifications Practice Guide, MasterFormat, SectionFormat, and PageFormat.

Specifier Notes: This Section must be carefully reviewed and edited by the Architect or Engineer to meet the requirements of the Project and local building code. Coordinate this Section with Division 01, other specification sections, and the Drawings. Delete all Specifier Notes after editing this Section.

Section numbers and titles are based on MasterFormat 2016 Update.

SECTION 23 57 00

HEAT EXCHANGERS FOR HVAC

Specifier Notes: This Section covers Fantech's HERO Heat Recovery Ventilators. Consult Fantech for assistance in editing this Section as required for the Project.

PART 1. GENERAL

1.1 SECTION INCLUDES

- A. Heat Recovery Ventilators.

1.2 RELATED REQUIREMENTS

Specifier Notes: Edit the following list of related sections as required for the Project. Limit the list to sections with specific information that the reader might expect to find in this Section but is specified elsewhere.

- A. Section 23 08 00 – Commissioning of HVAC.

1.3 REFERENCE STANDARDS

Specifier Notes: List reference standards used elsewhere in this Section, complete with designations and titles. Delete reference standards from the following list not used in the edited Section.

- A. ANSI/AMCA 300 – Reverberant Room Method for Sound Testing of Fans.
- B. CSA C22.2, No. 113 – Fans and Ventilators.
- C. CSA C439 – Laboratory Methods of Test for Rating the Performance of Heat/Energy-Recovery Ventilators.
- D. CSA F326 – Residential Mechanical Ventilation Systems.
- E. IEC 60529 – Ingress Protection Test Standard.
- F. ISO 9001:2015 – Quality Management Systems – Requirements.
- G. NFPA 70 – National Electrical Code (NEC).
- H. UL723 – Standard for Test for Surface Burning Characteristics of Building Materials.
- I. UL900 – Standard for Safety Air Filter Units.
- J. UL1004 – Standard for Safety Electric Motors.
- K. UL1812 – Standard for Ducted Heat Recovery Ventilators.

1.4 PREINSTALLATION MEETINGS

Specifier Notes: Edit the Preinstallation Meetings article as required for the Project. Delete article if not required.

- A. Convene preinstallation meeting [1 week] [2 weeks] before start of Work of this Section.

- B. Require attendance of parties directly affecting Work of this Section, including Contractor, Architect, installer, and manufacturer's representative.
- C. Review the Following:
 - a. Materials
 - b. Installation
 - c. Adjusting
 - d. Protection
 - e. Coordination with other Work

1.5 SUBMITTALS

Specifier Notes: Edit the Submittals article as required for the Project. Delete submittals not required.

- A. Comply with Division 01.
- B. Product Data: Submit manufacturer's product data, including installation instructions.
- C. Shop Drawings: Submit manufacturer's shop drawings, including plans, elevations, sections, and details.
 - a. Wiring Diagrams: Indicate wiring for each item of equipment and interconnections between items of equipment.
 - b. Include manufacturer's names, model numbers, ratings, power requirements, equipment layout, device arrangement, complete wiring point-to-point diagrams, and conduit layouts.
- D. Manufacturer's Certification: Submit manufacturer's certification that materials comply with specified requirements and are suitable for intended application.
- E. Operation and Maintenance Data:
 - a. Submit manufacturer's operation and maintenance manual; including the following:
 - i. Operation, maintenance, adjustment, and cleaning instructions.
 - ii. Troubleshooting guide
 - iii. Parts list
 - iv. Electrical wiring diagrams if required.
 - b. Provide detailed information required for Owner to properly operate and maintain equipment.
- F. Warranty Documentation: Submit manufacturer's standard warranty.

1.6 QUALITY ASSURANCE

- A. Manufacturer's Qualifications:
 - a. Manufacturer regularly engaged in the manufacturing of air handling units, heat, or energy recovery ventilators in the last 10 years.
 - b. ISO 9001 Certified
- B. Installer's Qualifications:
 - a. Installer regularly engaged in installation of air handling units, heat, or energy recovery ventilators to that specified for a minimum of 5 years.
 - b. Use persons trained for installation of air handling units, heat or energy recovery ventilators

1.7 DELIVERY, STORAGE, AND HANDLING

- A. Delivery Requirements: Deliver materials to site in manufacturer's original, unopened containers, and packaging, with labels clearly identifying product name and manufacturer.
- B. Storage and Handling Requirements:
 - a. Store and handle materials in accordance with manufacturer's instructions.
 - b. Keep materials in manufacturer's original, unopened containers, and packaging until installation.
 - c. Store materials in clean, dry area indoors.
 - d. Keep materials from freezing.
 - e. Protect materials during storage, handling, and installation to prevent damage.

1.8 WARRANTY

Warranty Period: Limited lifetime on counterflow exchanger, 7 years on motors, and 5 years on parts.

PART 2. PRODUCTS

2.1 MANUFACTURERS

- A. Manufacturer: Fantech Inc., 50 Kanalfakt Way, Bouctouche, New Brunswick E4S 3M5, Canada. For Canada: Toll Free 800-565-3548, CANADAsupport@fantech.net For USA: Toll Free 800-747-1762, USsupport@fantech.net Specifier Notes: Specify if substitutions will be permitted.
- B. Substitutions: [Not permitted] [Comply with Division 01].
- C. Single Source: Provide materials from single manufacturer.

2.2 HEAT RECOVERY VENTILATORS

- A. Heat Recovery Ventilators:
 - a. Model: HERO 120H, HERO 150H, HERO 200H, HERO-150H-EC, HERO 250H-EC
 - b. Indoor, compact, residential Heat Recovery Ventilators.
- Specifier Notes: Specify required model. Consult Fantech for assistance in determining Heat Recovery Ventilator model for the specific application.*
- B. General
 - a. Each Unit or Group of Units: Capable of operating in any mode independently or dependently of other systems.
 - b. Listed under CSA C22.2, No. 113/UL 1812.
 - c. Wiring: NFPA 70.
 - d. Performance: As scheduled on the Drawings.

- e. Equipped with a control system.
- f. Performs all functions necessary for operation.
- g. Capable of changing modes with no interruption to system operation.
- h. Capable of transferring sensible heat between the fresh and stale air streams.
- i. Capable of operating in winter and summer conditions without imbalance or loss of ventilation capacity greater than specified in design.

C. Unit Cabinet

- a. Single Wall Cabinet:
 - i. 22-gauge galvanized corrosion resistant steel casing.
 - ii. Seams: Sealed, requiring no caulking in field.
- b. Insulation within a Single Wall:
 - i. .75-in. (20-mm) of high-density expanded polystyrene.
 - ii. Flame Spread Index, UL 723: Not over 25.
 - iii. Smoke Developed Index, UL 723: Not over 50.

D. Cabinet Doors & Panels

- a. 22-gauge galvanized pre-painted door
- b. .75-in. (20-mm) of high-density expanded polystyrene.

E. Fans

- a. Factory-balanced fans with backward curved blades.
- b. Fan Motors:
 - i. Maintenance-free, permanently lubricated, sealed ball bearings.
 - ii. Thermal overload protected (TOP).
 - iii. UL listed to UL1004 and/or UL2111, CSA C22.2 No. 77 and No.100.
 - iv. IP Protection, according to IEC 60529
 - 1. Class 44 for HERO 120H, HERO 150H & HERO 200H
 - 2. Class 54 for HERO 150H-EC & HERO 250H-EC
- c. Separate fans for exhaust and supply blowers.

F. Heat recovery core

- a. Construction: Aluminum frame with flame rated plastic plates which are designed to transfer sensible heat. The flame spread index of the heat recovery exchanger shall not be over 25 and its smoke developed index shall not be over 50 when tested in accordance with the Standard for Tests for Surface Burning Characteristics of Building Material, UL723. The HRV Core is freeze tolerant and water washable.
- b. Counter-flow construction type.
- c. Frame Material: Aluminum
- d. Effectiveness of exchanger: Documented in accordance with ASHRAE 84 and certified to AHRI 1060.
- e. Flame Spread Index, heat recovery exchanger, UL 723: Not over 25.
- f. Smoke Developed Index, heat recovery exchanger, UL 723: Not over 50.

G. Air filters

- a. Supply and exhaust air protected by 2 MERV-3 washable electrostatic panel type air filters.
- b. Optional MERV-8 or MERV-13 supply air filters can be added and used along with the standard MERV-3

H. Frost prevention

- a. Frost prevention sequence (pre-set) initiated if the outdoor air temperature falls below the set point of 23°F (-5°C).

I. Electrical 1 Phase Input Voltage

- a. Electrical Power: 120 VAC, 1 Phase, 60 Hz, MOP 15A.
- b. Internal Electrical Components:
 - i. Factory wired for single-point power connection.
 - ii. UL Listed or Recognized and CSA Certified or Accepted where applicable and wired in compliance with the National Electrical Code.

J. Electrical Box Components: Accessible without stopping unit or opening doors.

K. Electrical Box:

- a. Isolated from airflow paths.
- b. Protect integral wires and connections.

L. Serviceability

- a. Access Panel: Hinged and/or screwed access panel on front of unit.
- b. Heat recovery exchangers, filters, and motors: serviceable from front of unit.
- c. Fan Assemblies: mounted on removable sliding base.
- d. Heat recovery exchangers and filters: mounted on slide-out rails.

2.3 ACCESSORIES

Specifier Notes: Delete accessories not required

A. HERO 120H

- a. CO2 Sensor: model CO2RT-R
- b. TVOC Sensing Control: model ECO-Touch Auto IAQ
- c. Insulated Flex Duct: model FIDT 5
- d. Plastic Supply/Exhaust Hoods: model COM5P
- e. Metal Supply Grill: model MGS 5

- f. Metal Exhaust Grill: model MGE 5
- g. Fault Indicator Display System: FID Compliance Kit (Both packages required)
- B. HERO 150H
 - a. CO2 Sensor: model CO2RT-R
 - b. TVOC Sensing Control: model ECO-Touch Auto IAQ
 - c. Insulated Flex Duct: model FIDT 6
 - d. Plastic Supply/Exhaust Hoods: model COM6P
 - e. Metal Supply Grill: model MGS 6
 - f. Metal Exhaust Grill: model MGE 6
 - g. Fault Indicator Display System: FID Compliance Kit (Both packages required)
- C. HERO 150H-EC
 - a. CO2 Sensor: model CO2RT-R
 - b. TVOC Sensing Control: model ECO-Touch Auto IAQ
 - c. Insulated Flex Duct: model FIDT 6
 - d. Plastic Supply/Exhaust Hoods: model COM6P
 - e. Metal Supply Grill: model MGS 6
 - f. Metal Exhaust Grill: model MGE 6
 - g. Fault Indicator Display System: FID Compliance Kit (Both packages required)
- D. HERO 200H
 - a. CO2 Sensor: model CO2RT-R
 - b. TVOC Sensing Control: model ECO-Touch Auto IAQ
 - c. Insulated Flex Duct: model FIDT 6
 - d. Plastic Supply/Exhaust Hoods: model COM6P
 - e. Metal Supply Grill: model MGS 6
 - f. Metal Exhaust Grill: model MGE 6
- g. Fault Indicator Display System: FID Compliance Kit (Both packages required)
- E. HERO 250H-EC
 - a. CO2 Sensor: model CO2RT-R
 - b. TVOC Sensing Control: model ECO-Touch Auto IAQ
 - c. Insulated Flex Duct: model FIDT 6
 - d. Plastic Supply/Exhaust Hoods: model COM6P
 - e. Metal Supply Grill: model MGS 6
 - f. Metal Exhaust Grill: model MGE 6
- g. Fault Indicator Display System: FID Compliance Kit (Both packages required)

2.4 ASSEMBLY

- A. Factory assembled and wired heat recovery ventilators.

2.5 SOURCE QUALITY CONTROL

- A. Run test at factory.

PART 3. EXECUTION

3.1 EXAMINATION

- A. Examine areas to receive heat recovery ventilators.
- B. Notify Architect of conditions that would adversely affect installation or subsequent use.
- C. Do not begin installation until unacceptable conditions are corrected.

3.2 PREPARATION

- A. Prepare surfaces where heat recovery ventilators are to be mounted.
- B. Ensure surfaces are flat, level, plumb, and can support weight of heat recovery ventilators.

3.3 INSTALLATION

- A. Install heat recovery ventilators in accordance with manufacturer's instructions at locations indicated on the Drawings.
- B. Unit is typically hung by using metal mounting bracket supplied with unit.
- C. Optional chain kit available.
- D. Install heat recovery ventilators in accordance with NFPA 70.
- E. Do not expose electronic components to temperatures below 32 degrees F (0 degrees C) or above 122 degrees F (50 degrees C).

3.4 ADJUSTING

- A. Adjust heat recovery ventilators for proper operation in accordance with manufacturer's instructions.

3.5 DEMONSTRATION

- A. Demonstration
 - a. Demonstrate that heat recovery ventilators function properly in every respect.

- b. Provide hands-on demonstrations of operation of system components and complete system, including user-level program changes and function.
- c. Provide instruction and training by factory-trained and certified representative of manufacturer.

3.6 PROTECTION

- A. Protect installed heat recovery ventilators from damage during construction.

END OF SECTION